

DESANDER SMD 100

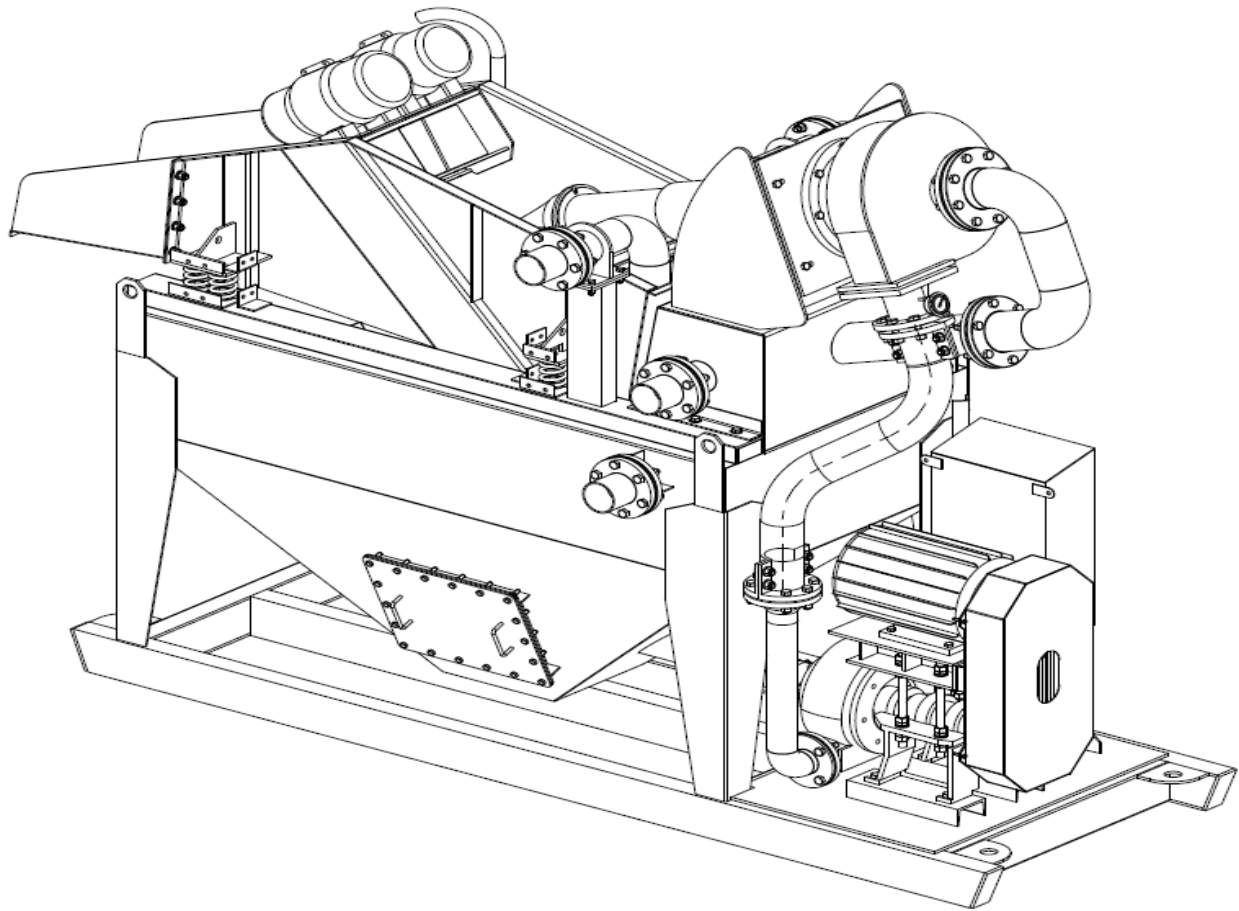

MAIN FEATURES

INSTALLED POWER	11 KW
TANK VOLUME	1.0 CU. MTRS
SEPARATION RATE	90 CU . MTRS/HR
MAIN SCREEN	0.78 SQ.MTRS
SECONDARY SCREEN	0.9 SQ.MTRS
HYDROCYCLONE DIAMETER	1 x 11" (1x280mm)
LENGTH	3.8 MTRS.
WIDTH	1.5 MTRS.
HEIGHT	2.6 MTRS.
WEIGHT	2300 KG.