

# DESANDER SMD 150

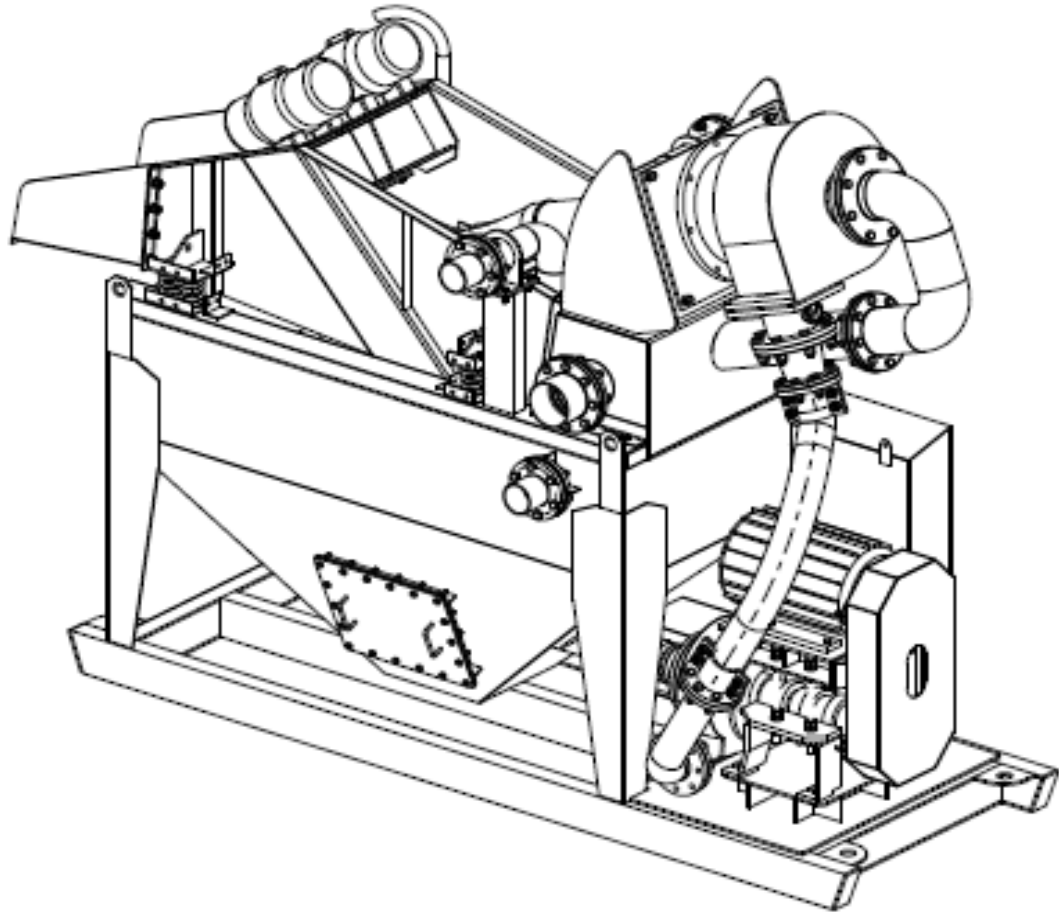

MAIN FEATURES	
INSTALLED POWER	18.5 KW
TANK VOLUME	1.5 CU. MTRS
SEPARATION RATE	140 CU . MTRS/HR
MAIN SCREEN	0.93 SQ.MTRS
SECONDARY SCREEN	1.06 SQ.MTRS
HYDROCYCLONE DIAMETER	1 x 15" (1x381mm)
LENGTH	3.8 MTRS.
WIDTH	1.6 MTRS.
HEIGHT	2.3 MTRS.
WEIGHT	2800 KG.