

DESANDER SMD 250

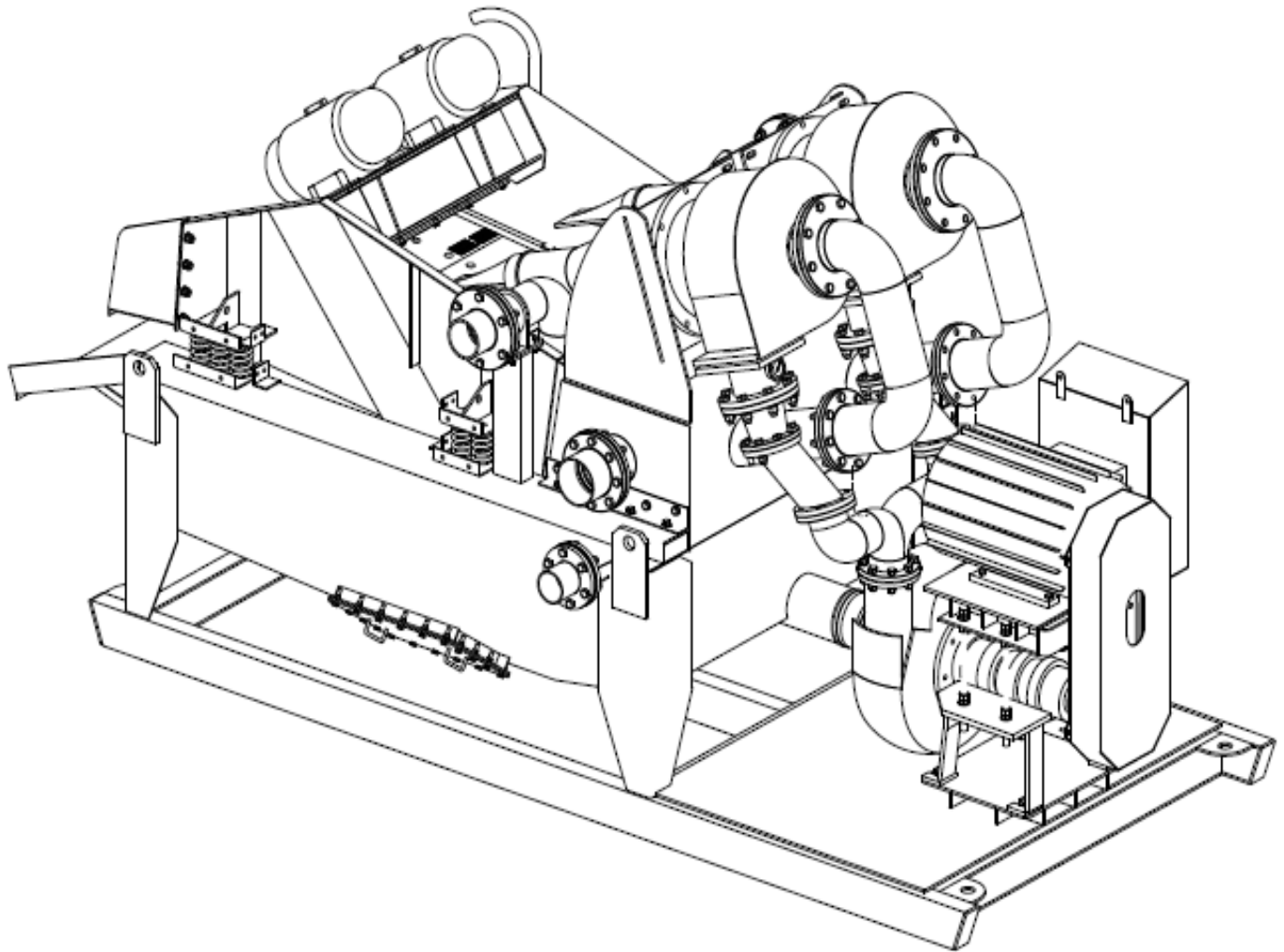

MAIN FEATURES	
INSTALLED POWER	30 KW
TANK VOLUME	2.0 CU. MTRS
SEPARATION RATE	240 CU . MTRS/HR
MAIN SCREEN	1.43 SQ.MTRS
SECONDARY SCREEN	1.8 SQ.MTRS
HYDROCYCLONE DIAMETER	2 x 15" (2x381mm)
LENGTH	4.3 MTRS.
WIDTH	1.9 MTRS.
HEIGHT	2.2 MTRS.
WEIGHT	5400 KG.